

MOWOX[®]

PM 5175 SHW

G.W.: 35.9 KG
N.W.: 32.1 KG



6 932495 608970



MOWOX®

PM 5175 SHW COMFORT SERIES



CAUTION
WILD INSIDE



- ZENTRALE HÖHENVERSTELLUNG
- CENTRAL HEIGHT ADJUSTMEN
- RÉGLAGE CENTRAL DE LA HAUTEUR
- GEWEBESACK MIT FÜLLSTANDSANZEIGE
- GRASS BAG WITH LEVEL INDICATOR
- SAC EN TEXTILE AVEC AFFICHAGE DU NIVEAU DE REMPLISSAGE
- RÄDER MIT KUGELLAGER
- WHEEL WITH BALL BEARINGS
- ROUES AVEC ROULEMENT À BILLES

- cutting width 51cm
- 1800 m²
- 171cc 3,5 PS, 2,6kW 2800 rpm
- start
- 10x, 25-75mm
- 3in1 collecting mulching side discharging
- 60 l fill level indicator
- metal chassis
- self drive
- 200 / 280mm
- quick release
- waterclean
- edge cutting
- 32.1 kg weight

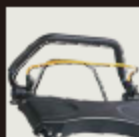
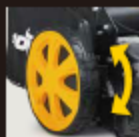
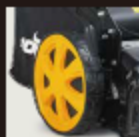

MOWOX®

PM 5175 SHW COMFORT SERIES



Strong in traction:
XL-wheels for more traction and comfort

Quickly clean again:
hose connection for standard garden hoses

3 in 1 function:
1. mowing / collecting
2. mowing / mulching
3. mowing / side discharge

Comfortable:
central cutting height adjustment

Easy good in the hand:
handle with soft grip



Traktionsstärker:
XL-Antriebsräder für mehr Traktion und Komfort.

Schnell wieder sauber:
Waschanschluss inklusive Schlauchanschluss für handelsübliche Gartenschläuche.

3 in 1 Funktion:
1. Mähen / Fangen.
2. Mähen / Mulchen.
3. Mähen / Auswerfen.

Komfortabel:
Zentrale Schnitthöhenverstellung.

Gut in der Hand:
Oberholm mit Soft-Grip



Force de traction :
roues motrices XL pour plus de traction et un plus grand confort.

Nettoyage rapide :
orifice de lavage, raccord de tuyau inclus pour tuyaux d'arrosage usuels.

Fonction 3 en 1 :
1. Tonte / Ramassage.
2. Tonte / Paillage.
3. Tonte / Ejection.

Confortable :
réglage central de la hauteur de coupe.

Bien en main :
guidon supérieur avec poignée souple.



English

Mower housing	steel
Engine	Mowox DG750, 171 cc/DHV
Capacity	2,6 kw at 2800 rpm
Self-propelled	yes
Cutting width	51 cm
Cutting height adjustment	10-stage, 25-75 mm, central
Grass bag	60 L plastic/textile
For lawn areas up to	1800 m ²
Further features	handle with quick-release function, hose connection



Français

Carter de coupe	Acier
Moteur	Mowox DG750, 171 cc/DHV
Puissance appr. (nominale)	2,6 kw à 2800 u/min
Propulsion	Oui
Largeur de coupe	51 cm
Réglage de la hauteur de coupe	10 niveaux, 25-75 mm, central
Panier collecteur	60 L, matière plastique/textile
Pour des pelouses jusqu'à env.	1800 m ²
Autre	Guidon avec fonction de verrouillage rapide Orifice de lavage



Italiano

Teleso	acciaio
Motore	Mowox DG750, 171 cc/DHV
Potenza	2,6 kw a 2800 g/min.
Semovente	sì
Larghezza di taglio	51 cm
Regolazione dell'altezza di taglio	10 posizioni, 25-75 mm, centralizzata
Capacità sacco	60 L top plastica/tela
Area di taglio fino a	1800 m ²
Ulteriori caratteristiche	impugnatura con sistema quick-release (sgancio rapido), connettore tubo per lavaggio



Nederlands

Maaiërbehuizing	Staal
Motor	Mowox DG750, 171 cc/DHV
Vermogen (ong.) (nominaal)	2,6 kw bij 2800 omw./min
Aandrijving	Ja
Maaiërbreedte	51 cm
Maaiërhoogte	10-traps, 25-75 mm, centraal
Opvangbak	60 L kunststof/textiel
Voor gazons tot ong.	1800 m ²
Overige	Handel met snelspanfunctie Wass aansluiting



Čeština

kryt žacího ústrojí	ocel
motor	Mowox DG750, 171 cc/DHV
výkon cca (men.)	2,6 kw při 2800 ot./min.
pohon	ano
šířka záběru	51 cm
nastavení výšky sečení	10 stupňová, 25-75 mm, centrálně nastavitelná
sběrný koš	60 l plast/textil
na trávníkové plochy do cca	1800 m ²
ostatní	rukojeť s rychlopaní funkcí připojka na mytí



Magyar

Fűnyírőház	Acsél
Motor	Mowox DG750, 171 cc/DHV
Kb. teljesítmény (névleges)	2,6 kW 2800 ford/perc fordulatszámon
Hajtás	Igen
Vágásmélység	51 cm
Vágásmélységállítás	10 fokozatú, 25-75 mm, központi
Gyűjtőkosár	60 l műanyag/textil
Fűterület mérete legfeljebb kb.	1800 m ²
Egyéb	Rúd gyorsrögzítő funkcióval mosás csatlakozás



Deutsch

Mähgehäuse	Stahl
Motor	Mowox DG750, 171 cc/DHV
ca. Leistung (Nenn)	2,6 kW bei 2800 U/min
Antrieb	Ja
Schnittbreite	51 cm
Schnitthöhenverstellung	10 stufig, 25-75 mm, zentral
Fangkorb	60 L Kunststoff/Textil
Für Rasenflächen bis ca.	1800 m ²
Sonstiges	Handl. mit Schnellspanfunktion Waschanschluss



Español

Carcasa de la cortadora	Acero
Motor	Mowox DG750, 171 cc/DHV
Potencia aprox. (nominal)	2,6 kW con 2800 r.p.m.
Accionamiento	Si
Ancho de corte	51 cm
Ajuste de altura de corte	10 niveles, 25-75 mm, centralizado
Cesta colectora	60 L plástico/tela
Para superficies de césped de aprox.	1800 m ²
Otros	Larguero con función de fijación rápida Conexión de lavado



Português

Alojamento do corte-rodas	Aço
Motor	Mowox DG750, 161 cc/DHV
Potência aprox. (nominal)	2,6 kW a 2800 rpm
Sistema de propulsão	Sim
Langura de corte	51 cm
Ajuste da altura de corte	10 níveis, 25-75 mm, central
Cesto de recolha	60 L plástico/tela
Para superfícies relvadas até aprox.	1800 m ²
Outro	Coçura com função de extensão rápida Ligação para lavagem



Polski

Obudowa kosiarzki	Stal
Silnik	Mowox DG750, 171 cc/DHV
Moc w przybliżeniu (nomin.)	2,6 kW przy 2800 1/min
Napęd	Tak
Szerokość cięcia	51 cm
Regulacja wysokości cięcia	10-stopniowa, 25-75 mm, centralna
Kosz	60 l tworzywo sztuczne/tkanina
Do powierzchni trawniowych do ok.	1800 m ²
Pozostałe	Uchwyt z funkcją szybkiego zaciskania Przyłącze do mycia



Slovenčina

kryt žacieho ústrojenstva	ocel
motor	Mowox DG750, 171 cc/DHV
výkon cca (men.)	2,6 kW pri 2800 ot./min
pohon	áno
šířka záběru	51 cm
nastavenie výšky kosenia	10-stupňová, 25-75 mm, centrálna nastaviteľná
zberný koš	60 l plast/textil
na trávnikové plochy do cca	1800 m ²
ostatné	rukojeť s rýchlopaníou funkciou prípojka na umývanie



Română

Carcasă cositoare	Oțel
Motor	Mowox DG750, 171 cc/DHV
Putere aprox. (nom.)	2,6 kW la 2800 rot./min
Motor	Da
Lățime de tăiere	51 cm
Ajustare înălțime de tăiere	cu 10 trepte, 25-75 mm, central
Coș de colectare	60 L din mat. plastic/textil
Pentru suprafețe de câșpit până la aprox.	1800 m ²
Alte	Mâner cu blocare rapidă Record pentru spălare

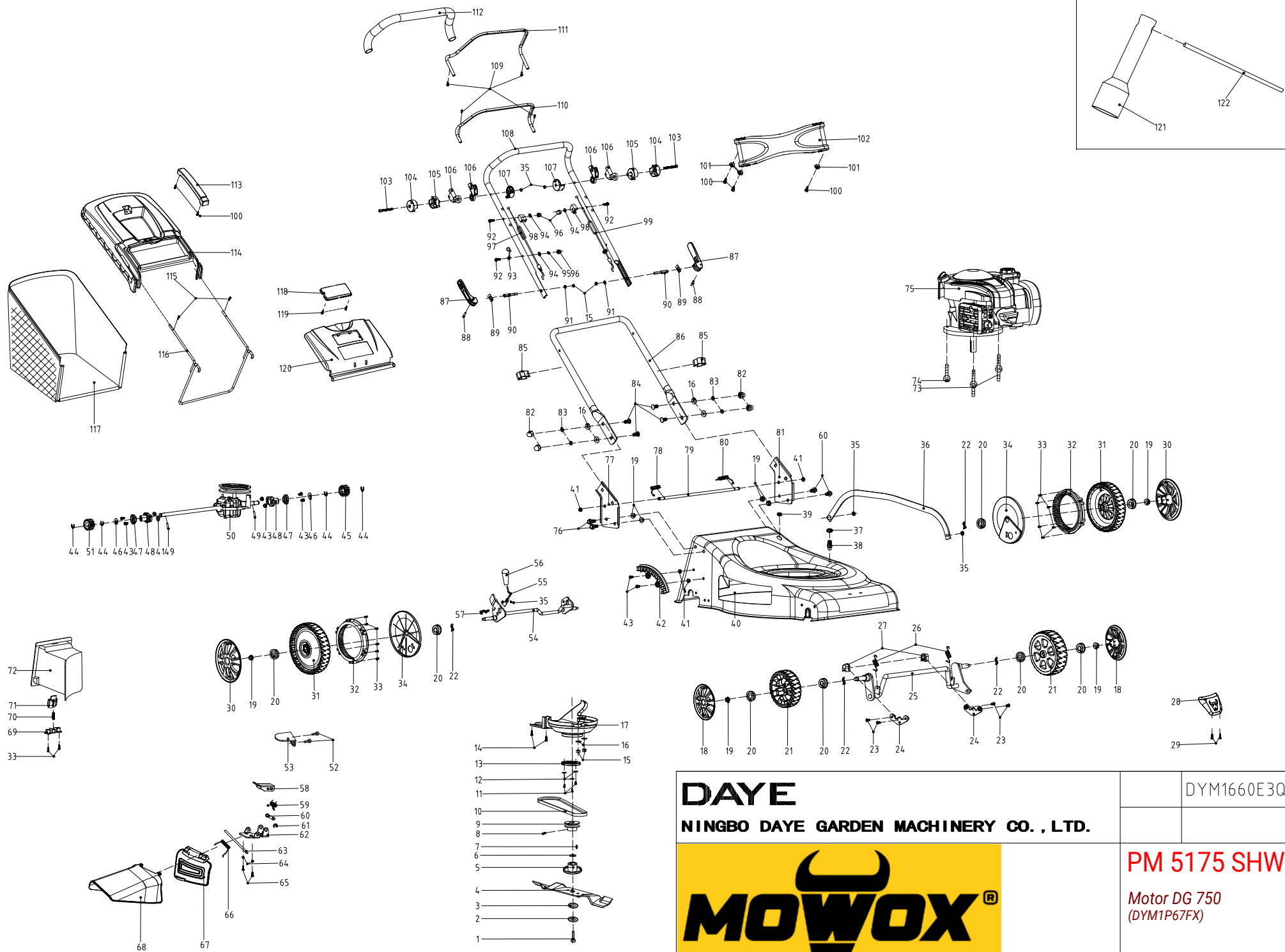

DAYE
NINGBO DAYE GARDEN MACHINERY CO., LTD.



DYM1660E3Q

PM 5175 SHW

Motor DG 750
 (DYM1P67FX)

in sketch	part number	other number of same part	part description	Qty
1	2105300159A	A26800606201	Blade fastening bolt	1
2	2105300001C	26300107302	dish washer	1
3	2105200245A	2105200367A	Friction tool holder pressure plate	1
4	21052002622000A	2105200262A	blade	1
5	2105200251A		- Stamping tool holder	1
6	2105400051A		- Tool holder bushing	1
7	2103900034A		- half round key	1
8	3022305001	26800300502	Hexagon socket flat end set screws	1
9	21031003390082A		- Driving pulley	1
10	2102600016A	2102600016N	V-belts	1
11	3011301018	A26800102101	Self-tapping screws	3
12	3051205001	A26800700502	Flat Washers	3
13	2104600006A		- Dust cover	1
14	3011301006		- Self-tapping screws	2
15	3031309002		- Hexagonal lock nut	4
16	3051303001		- Flat Washers	6
17	21041002600001N	25288400102	belt protector	1
18	21011000560103B	25205001101	8" wheel cover	2
19	30323060035000	26800502801	Hex flange face lock nut	8
20	2101300065A	26800401601	Angular bearings	8
21	21011002660001A	21011002443208C	wheel assembly	2
22	A26800706202	26800706202	Wave washer	4
23	3021302003		- Machine screws	4
24	2101200011B	26300134202	Axle fixed pressure plate	2
25	2101500068D		- Front axle assembly	1
26	2109800049B	26801110001	Front axle tension spring	2
27	21011000290001A	25202600101	Front axle retaining ring	2
28	21031002334079A		- Head mask assembly	1
29	3011301012	26800105402	Self-tapping screws	2
30	21011000620103N	25208601001	11" wheel covers	2
31	21011002650001A	25400204502	wheel assembly	2
32	2101100081B	25229500101	wheel ring gear	2
33	3011301010		- Self-tapping screws	14
34	21011003730001F	25208700105	11" dust wheel cover	2
35	30313090035000	A26800500501	Hexagonal lock nut	6
36	2106200047C	23600403202	link	1
37	2109100013N	25100135101	O-ring	1

in sketch	part number	other number of same part	part description	Qty
38	21031000230176D	25214300301	Clean connectors	1
39	2106600013A	25100181601	cable protection cover	1
40	21032002480001A		- Mowing disc assembly	1
41	30323060015000	3032306001	All metal hex flange face lock nut	8
42	21061001694017B	23100105302	Gear plate	1
43	30213020045000	26800202001	Machine screws	6
44	3043301001		- Open retaining ring	4
45	2104400013E	26900300102	Left output gear assembly	1
46	A26800705901	26800705901	Flat gasket	2
47	21011004410001A		- spacer	2
48	21011004420120B		- rear axle sleeve	2
49	3082301003		- Cylindrical pin	2
50	2102300071C	23050200201	Gearbox assembly	1
51	2104400014E	26900300203	Right output gear assembly	1
52	30913050015000	A26800611201	Hexagon head flange bolts	2
53	2102300154A		- Positioning plate	1
54	2101300204A	2101500271A	rear axle assembly	1
55	2106201208A	2106201146A	handle assembly	1
56	21021000010001A	25500103201	Handlebar gloves	1
57	A26800203001A	26800203001	Cross recessed pan head screws	2
58	2103200233A		- Lock block B	1
59	2103800011A		- Lock block torsion spring	1
60	2103300040A		- Lock block fixed shaft	1
61	2103200228A		- Side row fixing plate	1
62	3043301003		- Open retaining ring	1
63	2106200053N	26200101901	Side row positioning shaft	1
64	3052301004		- spring washer	2
65	3021302002		- Machine screws	2
66	2109800066D	26801113004	Side cover torsion spring	1
67	21061000900001N	25231100102	Side row cover	1
68	21041001110001C		- Side row protective cover	1
69	21041001160001A	25231700101	Lock button pressure plate	1
70	2109800022C	26801100501	spring	1
71	21041001150001A	25231600401	Plug-in lock button	1
72	21061006910001A	21061003740001N	Grass cutting plug-in	1
73	2109900066A		- Triangular self tapping bolt	1
74	2109900067A		- Special bolts	2

in sketch	part number	other number of same part	part description	Qty
75	60400117401		- Gasoline engine (Euro V)	1
76	30913070165000	26800606401	Hexagon head flange bolts	4
77	21062004490001B	23600178201	Armrest right bracket	1
78	2106800006B	26801112701	Right-hand torsion spring	1
79	2101300006A	26300165601	long pole	1
80	2106800007A	26801112601	Left-hand torsion spring	1
81	21062004480001B	23600178101	Armrest left bracket	1
82	3033302001		- cap nut	4
83	3052301002		- spring washer	4
84	30913090015000	A26800601903	Round head square neck bolt	4
85	21061000013201A	25261100102A	Cable clip	2
86	21063001720001A		- Lower armrest	1
87	21061006503201A	21061000573201B	lock handle	2
88	21093000635007A		- Cylindrical pin	2
89	21062000015007A		- compression piece	2
90	21063000085007A		- Lock handle bolt	2
91	21092000295007B	2109200058A	Flat gasket	2
92	3091307003	A26800607701	Hexagonal flange bolts	3
93	21063000025007A		- Thread hook	1
94	3051303003		- Flat Washers	3
95	3052301003	A26800800303	spring washer	1
96	A26800501603A	26800501603	cap nut	3
97	2106800595B		- Flameout cable assembly	1
98	21061000043201A	25233600102	cable fixing block	2
99	2106800530A		- Drive cable assembly	1
100	3011301004	A26800104601A	Self-tapping screws	5
101	21061001113201N	25239100202	Curved gasket	3
102	21061004620001A		- armrest panel	1
103	3022301003		- Hexagon socket head screws	2
104	21061004573201A	21061004573201N	Tie rod outer positioning seat	2
105	21061004593201A	21061004593201N	Tie rod inner positioning seat	2
106	21061001803201B	25287600102	Self-propelled cable hanging block	4
107	21061001153206A	21061001153206N	Tie rod seat cover	2
108	21063001740001B		- Upper armrest	1
109	2109300058A		- Self-tapping screws	4
110	21062001990104A	23601070401	flameout lever	1
111	21062002080001A	23601018101	Drive rod	1

in sketch	part number	other number of same part	part description	Qty
112	2106600017A		- armrest cover	1
113	21071000330001A	25238400101	Grass basket handle	1
114	21071000310001A	25238200101	Grass basket	1
115	3011301005		- Self-tapping screws	2
116	2107200037B	2107200024C	Grass bag holder	1
117	21077000462133A	21077000462122A	straw bag	1
118	2104100134C	25238500103	Transparent window on back cover	1
119	A26800107101	26800107101	Self-tapping screws	2
120	2100X00589	23000427201	Rear cover assembly	1
121	2012100004A	26300107901	Socket wrench lever	1
122	2012200002A	26300107801	socket wrench	1

DG750

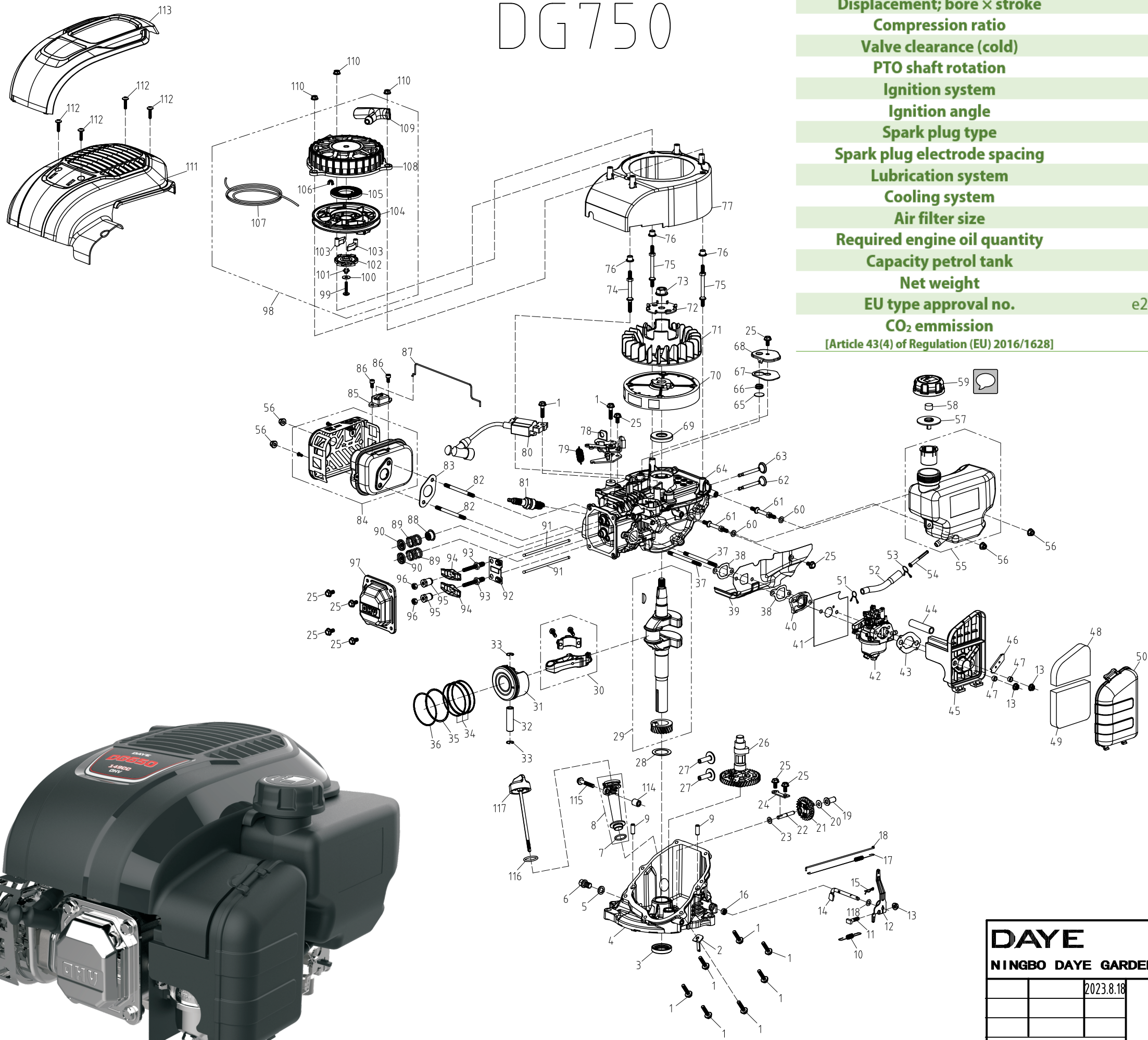

Engine design	4-stroke engine, overhead valve, 1 cylinder
Displacement; bore × stroke	171 cm ³ ; 67 × 48,4 mm
Compression ratio	8.8:1
Valve clearance (cold)	0.10 – 0.15 mm
PTO shaft rotation	clockwise
Ignition system	Transistor ignition
Ignition angle	16° ± 2°
Spark plug type	F6RTC
Spark plug electrode spacing	0.6 - 0.8 mm
Lubrication system	Immersion lubrication
Cooling system	Forced air cooling
Air filter size	326 × 308 × 342 mm
Required engine oil quantity	0.4 l
Capacity petrol tank	0.9 l
Net weight	7.9 kg
EU type approval no.	e24*2016/1628*2021/13985YA1/P*0544*00
CO₂ emission	930.4 g/kWh
[Article 43(4) of Regulation (EU) 2016/1628]	

DAYE		DG750
NINGBO DAYE GARDEN MACHINERY CO., LTD.		(DYM1P67FX)
2023.8.18		
	1:1	
	A2	604.00119101

DAYE

in sketch	part number	other number of same part	part description	weight/ g	Qty
1	3091307002		- Hexagon flange bolt M6 * 25		9
2	2032400042A		- Speed control fixing plate		1
3	2031600016N	25100123602	oil seal		1
4	2031400096B		- Box cover		1
5	2031300007A	26300225901	Oil drain plug gasket		1
6	2031300006A	26300205601	Oil drain plug		1
7	2039600019N	25100137602	O-ring		1
8	2030X00619	2030X00618	Oil dipstick holder assembly		1
9	2031300107A		- Locating pin		2
10	2033800004A		- Speed control tension spring		1
11	2031300012A	26800301101	Speed regulation screw		1
12	2031300063N	26300220401	Speed control rocker arm		1
13	3032302004		- Hexagon flange nut M6		3
14	2032300107A		- Speed control swing rod		1
15	2031200007A	26900103401	Elastic split pin		1
16	20316000007	25100123501	oil seal		1
17	20398000005A		- Throttle spring		1
18	20353000001A		- Throttle push rod		1
19	20321000007A		- Sliding sleeve		1
20	A26800703201	26800703201	Flat washer 6		1
21	2032300104A		- Speed control gear assembly		1
22	2032300097A		- Speed control gear shaft		1
23	3051204003		- Washers ϕ six		1
24	2031200015B	26300210102	Double hole pressing plate		1
25	3091307005		- Hexagon flange bolt M6 * 12		9
26	2032100022B		- Camshaft assembly		1
27	2033300027A		- Tappet		2
28	20322000003A	26800703102	Spacer		1
29	2032400048A		- Crankshaft assembly		1
30	2032400040A		- Connecting rod assembly		1
31	2032400047A		- piston		1
32	2032300105A		- Piston pin		1
33	20328000003A		- Piston pin circlip		2
34	2032900017A		- Oil ring combination		1
35	2032300124A		- Bicyclic		1
36	2032300125A		- One ring		1
37	A26800609901	26800609901	Stud		2
38	2036900044A		- Cylinder head and intake pipe sealing gasket		2
39	2039300048A		- Air guide plate		1

DAYE

in sketch	part number	other number of same part	part description	weight/ g	Qty
40	2036100057A		- Intake duct		1
41	2039900038A		- Carburetor and intake pipe sealing gasket		1
42	2035900022A		- carburetor		1
43	2036900045A		- Sealing gasket for carburetor and air filter		1
44	2035600007A		- Ventilation pipe		1
45	20351000100001A		- Air filter base		1
46	20351000110001A		- Inner cover of air filter		1
47	2031300008B	26809003101	Cushion Cover		2
48	2036900046A		- Air filter element A		1
49	2035900006A		- Air filter element B		1
50	20351000090001A		- Air filter cover		1
51	2035200035A	26900108001	Oil pipe clamp B		1
52	2035600008A		- Oil inlet pipe		1
53	2035200029A		- Tubing clamp		1
54	2035100016A	2035100003A	Fuel filter screen		1
55	2035100013A		- Fuel tank body		1
56	30323060015000		- All metal hexagonal flange locking nut M6		4
57	2034600003A		- Sealing gasket for fuel tank cover		1
58	2036900037A		- Filter sponge		1
59	20351000220001A		- Fuel tank cap		1
60	A26800707001	26800707001	Flat washer		2
61	2039300006A		- Double headed studs		2
62	2037300011D	26300206101	Exhaust valve		1
63	2031400087A		- Intake valve		1
64	2031400108A		- Box		1
65	2031600019A	25100129701	Breather valve plate		1
66	2039800007A		- Respirator pressure spring		1
67	2037900007A		- Respirator sealing gasket		1
68	2035900005A		- Respirator cover plate		1
69	2039600003A		- oil seal		1
70	2033400003A		- flywheel assembly		1
71	20331000530001A		- Fan		1
72	2032200011A		- Fan Platen		1
73	3032303001	A26800610501	Hexagon flange nut M12 * 1.25		1
74	2039300009A		- Double head stud A		1
75	2039300030A		- Double head stud B		2
76	2033300012A	26300211601	Air guide cover insert		3
77	20341000700001A		- Air guide cover		1
78	2032900015A		- Brake assembly		1

DAYE

in sketch	part number	other number of same part	part description	weight/ g	Qty
79	2039800006A		- Brake tension spring		1
80	2033900017A		- Igniter Assembly		1
81	2038900001C	2038900001B	spark plug		1
82	A26800610103	26800610103	Carburetor stud		2
83	2039900041A		- Silencer sealing gasket		3
84	2037300007A		- Silencer assembly		1
85	2033900009A		- Thermostat assembly		1
86	A26800308501	26800308501	Hexagon socket head cap screw		2
87	2039300069B		- Choke lever		1
88	2036200007A		- Oil shield		1
89	2035800003A		- Valve spring		2
90	2036300040A		- Valve spring seat		2
91	2036200011B	23055000501	Push rod assembly		2
92	2039900033A		- Push rod guide plate		1
93	2031300002C	26800605401	Adjusting bolts		2
94	2036200004A		- Valve rocker arm		2
95	2031200002D	26800502501	Adjusting the nut		2
96	2031300003C	26800502601	Tighten the nut		2
97	2035600009A		- Cylinder head cover		1
98	2040X00065		- Starter cover assembly		1
99	A26800300902	26800300902	Left hand tapping screw		1
100	3051302001		- Large washer 5		1
101	2033200033A		- Starter circlip		1
102	20331000460001A		- Cover plate		1
103	2033100048A		- Pawl		2
104	20331000490001A		- Starting wheel		1
105	2033800005A		- Return spring		1
106	2033300011N	26300209903	Starting cover circlip		1
107	2032800001A	29001001101	Pull rope		1
108	20341000190001A		- Starter cover		1
109	20331000010001B	25234300101	Handle		1
110	3032302005		- Hexagon flange nut M6		3
111	20341000380001A		- Outer cover		1
112	3011301042		- Self tapping screw ST4.8 * 20 F		4
113	20341000400126A		- Decorative cover		1
114	2039300062A		- Shaft sleeve		1
115	3091307003	26800607701	Hexagon flange bolt M6 * 35		1
116	2035600038A		- O-ring		1
117	2035900019		- Oil dipstick		1

DAYE

in sketch	part number	other number of same part	part description	weight/ g	Qty
118	203900071A		- Speed swinging rod gasket		1